

# The Debt Crisis in the Euro Zone

Status – Scenarios - Solutions

Prof. Dr. Rainer Stachuletz

Berlin School of Economics and Law

Hanoi, September 11th, 2012

1

Prof. Dr. Rainer Stachuletz – Vietnam National University – September 2012

## The Debt Crisis in the Euro Zone



Prof. Dr. Rainer Stachuletz – Vietnam National University – September 2012

# Content

## The State of the Art

Scenario 1 : Muddling Through – Is there a Highway from Austerity to Stability ?

Scenario 2 : Eurobonds – Joint Liability at National Sovereignty ?

Scenario 3 : Economic and Political Integration – The Price of Solidarity ?

Scenario 4 : Downfall of the Euro – The Free Trade Zone and the Political Union ?

Synthesis

3

## The State of the Art – High Indebtedness

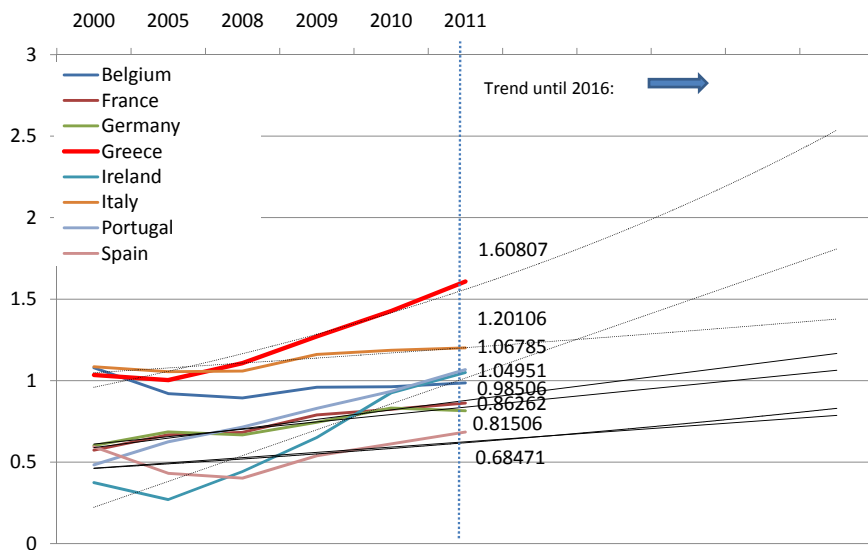

4

## The State of the Art – Ongoing Budget Deficits

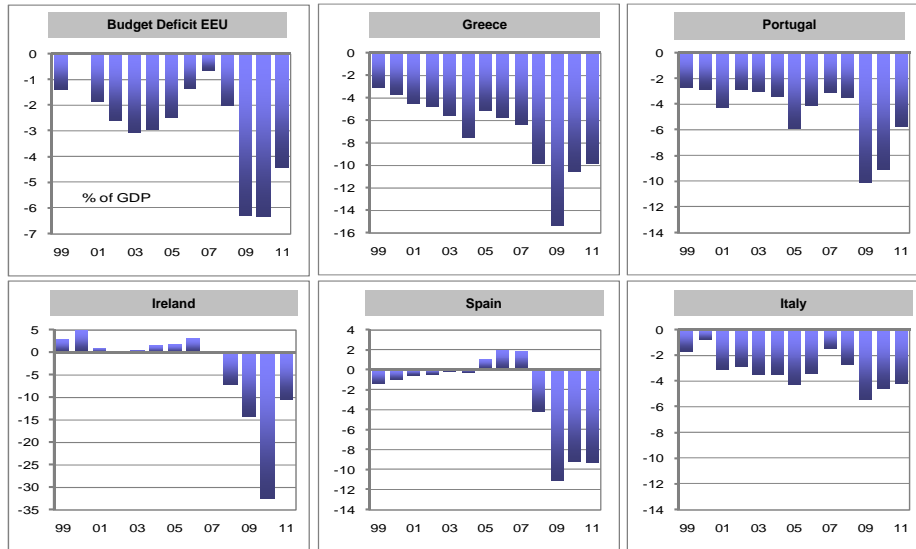

## The State of the Art - Regional Imbalances

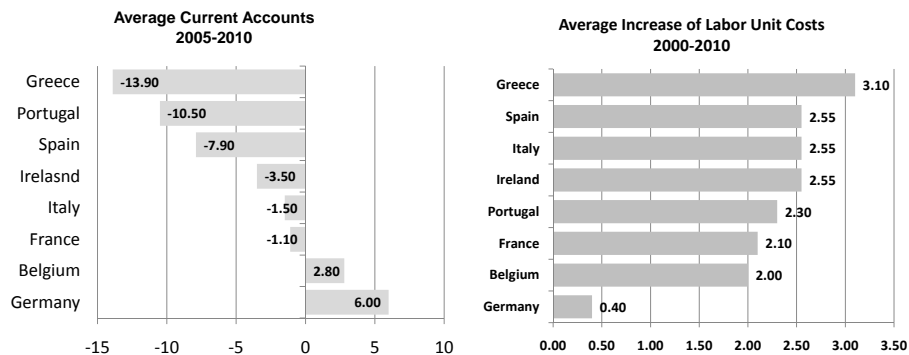

The Euro without a political and social union is an illusion. In the aftermath of the global financial crisis, the loss of sovereignty in monetary policy, different forms of moral hazard and irrational exuberances (credit financed bubble economies, unstable and clientel oriented fiscal policy) have led to significant imbalances in Europe. First answers to the problem have been given and should be proven by possible future scenarios.

## The State of the Art - Current Answers

### **European Financial Stability Facility (EFSF, founded 2010)**

- Capacity to buy bonds up to a value of 440 billion Euro
- Leverage mechanism to increase support of nation states by up to one trillion Euro
- EFSF is supposed to end on mid of 2013
- IMF increased its capacity to 250 billion Euro)

### **European Stability Mechanism (ESM, starting 2012)**

- Permant Mechanism with a capacity of 500 bio €
- Ratification by EMU member states necessary
- Provides monetary support under strict conditions (deficit < 0.5% unless total debt > 60%)
- Supervised by IMF and European Commission
- Elements of a fiscal union

7

Prof. Dr. Rainer Stachuletz – Vietnam National University – September 2012

## Muddling Through – Assumptions

The EMU remains unchanged, a further economic and political integration does not happen

All nations will ratify the stability and growth treaty, most countries will find back to the Maastricht criteria, situation in x-countries will improve.

Markets regain confidence in the Euro Zone, rescue funds will disappear.

8

Prof. Dr. Rainer Stachuletz – Vietnam National University – September 2012

## Muddling Through – Consolidation until 2020 ?

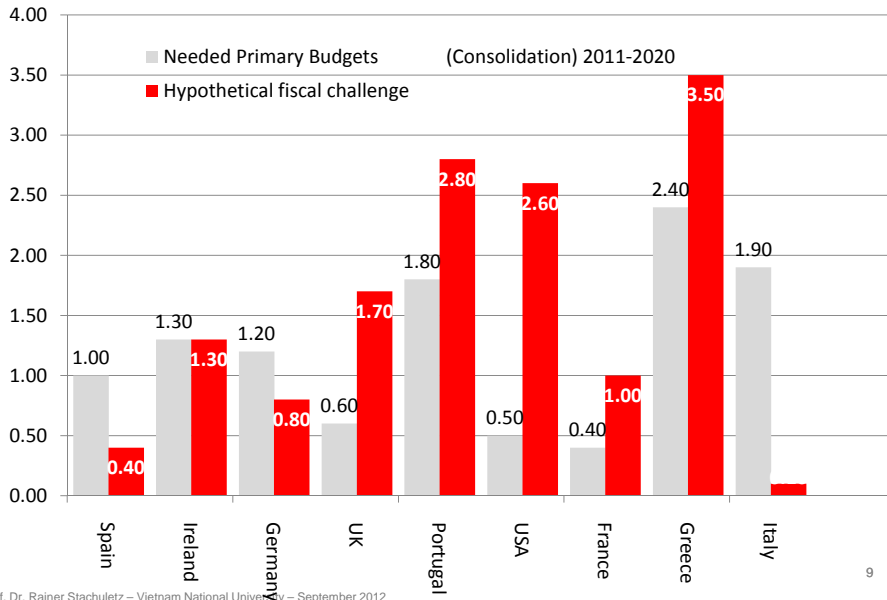

## Muddling Through – Back to Maastricht in 2020 ?

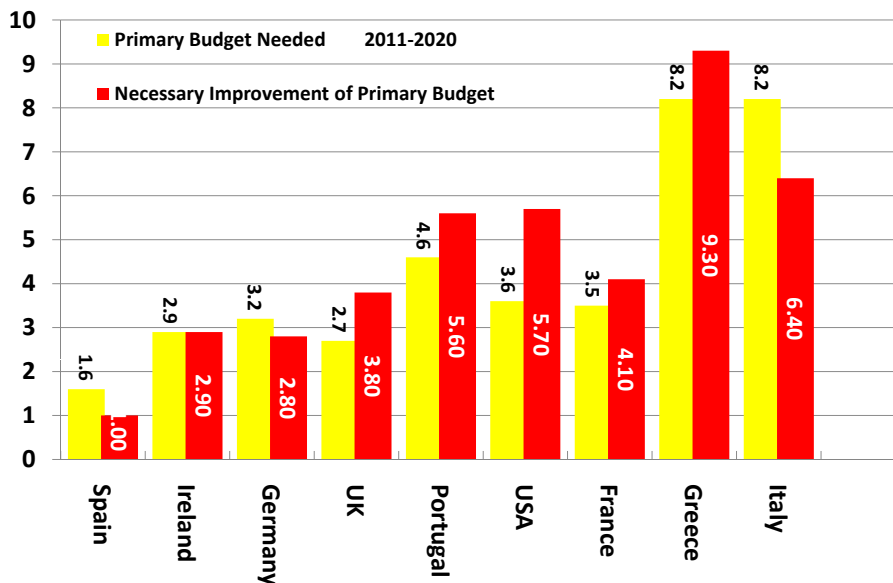

## Muddling Through – From Austerity to Stability ?

As recent studies show, it is most likely, that neither consolidation nor the Maastricht stability can be achieved just by budget discipline.

### Example:

Portugal (average budget deficit  $(G-T)/Y$  of 5%), expected mid term real growth rate of 1% and average real rates of 5.0% will – without any further action - yearly add additional debt of 9.4%  $(5\% - 1\%) \cdot 110\% + 5\%$  to it's debt stock :

$$\frac{B_t}{Y_t} - \frac{B_{t-1}}{Y_{t-1}} = (r - g) \cdot \frac{B_{t-1}}{Y_{t-1}} + \frac{(G_t - T_t)}{Y_t}$$

Prof. Dr. Rainer Stachuletz – Vietnam National University – September 2012

## Muddling Through – From Austerity to Stability ?

Austerity Programmes may lead to higher indebtedness

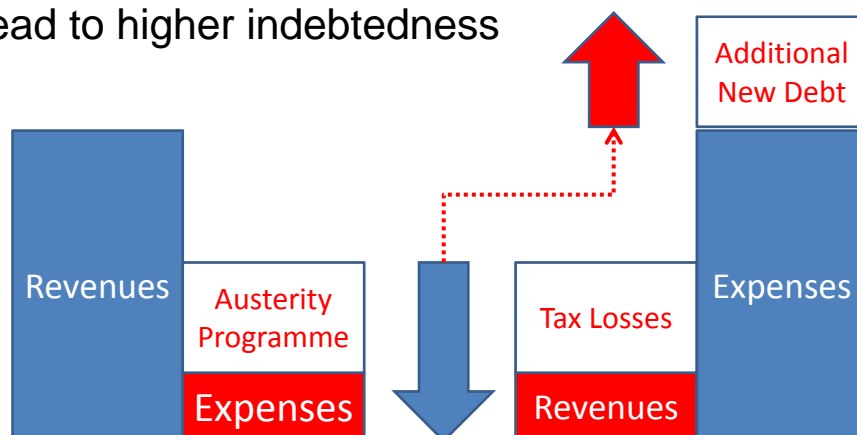

Prof. Dr. Rainer Stachuletz – Vietnam National University – September 2012

## Muddling Through – From Austerity to Stability ?

The European Debt Crisis contains – beside political problems - a stock and a flow problem. To regain stability, fiscal and economic measures are necessary. Right now, stock problems are being discussed as measures of fiscal policy. The flow problem is widely ignored.

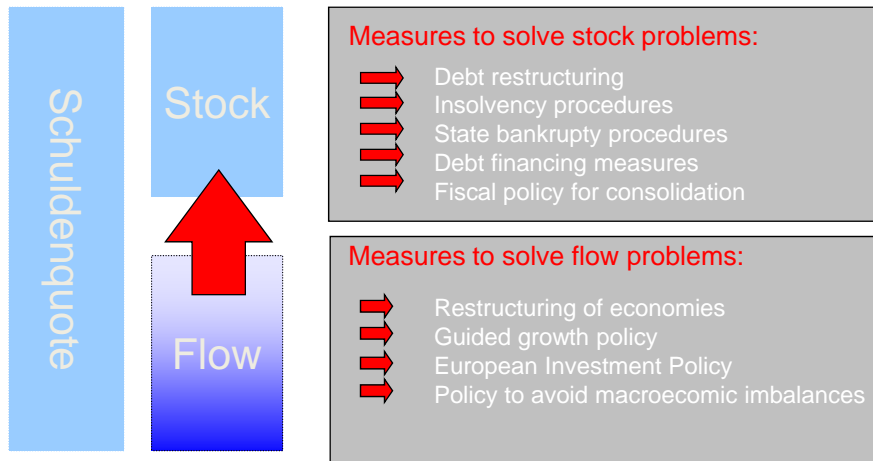

## Muddling Through – From Austerity to Stability ?

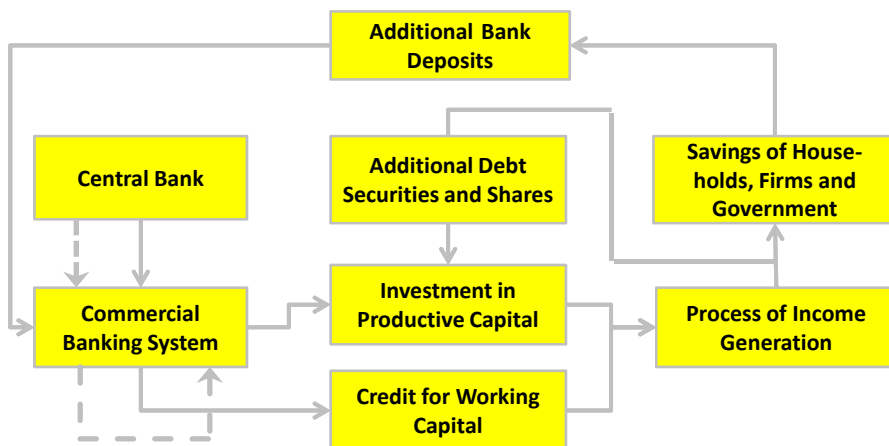

## Muddling Through – Outlook

- The EMU - treaty on stability and growth focuses on cuts in public expenditure and tax increases, actually spurring the slowdown of GDP
- Budget deficits cannot be closed, if debt to GDP ratios increase.
- Wage cuts provide deflationary tendencies, to enforce austerity policy has created political /social instabilities
- Deflation /low GDP growth generates instabilities in the banking system (Spain, Ireland, Portugal, Italy) . Due to the end of price bubbles the amount of bad debt increased.
- Fiscal policy alone will not be sufficient, the role and capacity of the EMS remains unclear.

15

Prof. Dr. Rainer Stachuletz – Vietnam National University – September 2012

## Eurobonds – Assumptions

- Public debt of sovereign nations will be financed by issuing Euro Bonds at collective liability of the EMU member countries.
- Harmonization of interest rates and financing costs allows to establish a mechanism to encounter regional imbalances and improve competition
- Euro Bonds are not accompanied by a deeper fiscal, social and political integration.
- Moral hazard effects are negligible.

16

Prof. Dr. Rainer Stachuletz – Vietnam National University – September 2012



## Eurobonds – Joint Liability at National Sovereignty ?

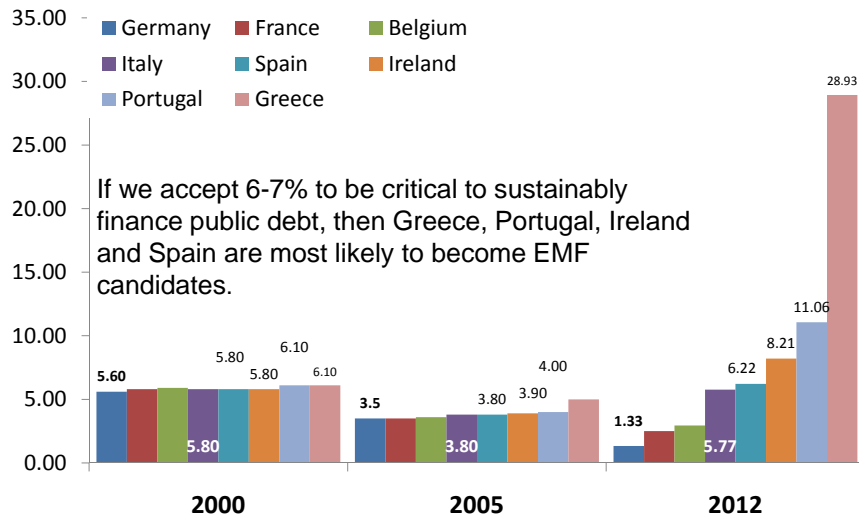

Prof. Dr. Rainer Stachuletz – Vietnam National University – September 2012

17

## Eurobonds – Joint Liability at National Sovereignty ?

COUNTRIES	GDP 2012 Bill. €	REFINANCING VOLUMES UNTIL 2013					
		2012		2013		Total	
		in %	Bill. €	in %	Bill. €	in %	Bill. €
FRANCE	2.047	20.8%	426	20.2%	414	41.0	840
ITALY	1.621	23.5%	380	18.9%	306	42.4%	686
GERMANY	2.627	10.5%	275	8.1%	214	18.6%	489
SPAIN	1.116	20.6%	229	19.4%	216	40.0%	445
BELGIUM	389	22.2%	87	21.8%	85	44.0%	172
PORTUGAL	170	22.3%	38	21.0%	36	33.3%	74
GREECE	217	16.5%	36	14.9%	32	31.4%	68
IRLAND	161	13.9%	22	14.9%	24	28.8%	46
<b>TOTAL</b>	<b>8.348</b>	<b>17,9%</b>	<b>1.493</b>	<b>15,9%</b>	<b>1.327</b>	<b>33,8%</b>	<b>2.820</b>
thereof:							
<b>X-Countries<sup>1</sup></b>	<b>3.285</b>	<b>21,5%</b>	<b>706</b>	<b>18,7%</b>	<b>615</b>	<b>40,2%</b>	<b>1.321</b>

Problem countries: Greece, Ireland, Italy, Portugal and Spain.

## Eurobonds – Joint Liability at National Sovereignty ?

- Current risk premiums for Greece, Portugal, Ireland and most likely Spain and Italy are too high to regain budget stability without ESM support.
- If capital markets do not provide sufficient resources at reasonable rates it is most likely, that the ESM capacity is too small to cover the refinancing needs over the next 18 months (total of 1,3 trillion €)
- ESM can either be adjusted stepwise (not recommended) or operate without upper limits based upon a bank license and unlimited access to capital markets guaranteed by the ECB.
- Fiscal, social and deeper political integration is under discussion/required.

## Eurobonds – Liability and Sovereignty ?

### Euro Bond Model Type A:

Euro countries transfer their total amount of public debt to an European agency (i.e. EMF) The EMF issues Euro Bonds to the financial markets. ECB guarantees market liquidity.

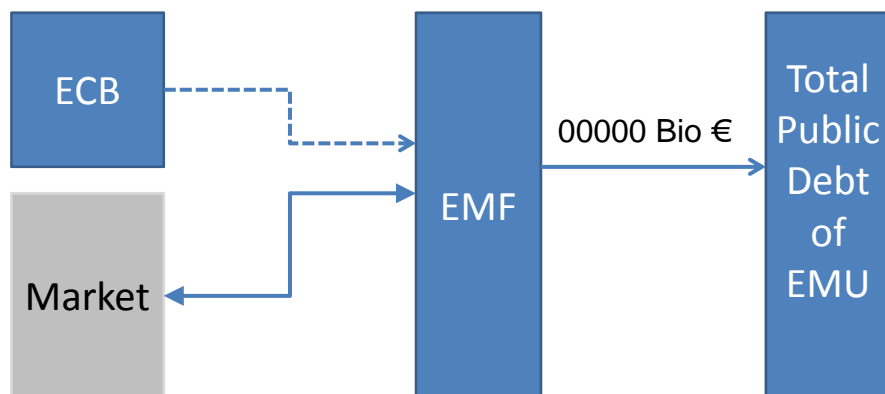

## Eurobonds – Liability and Sovereignty ?

### Euro Bond Model Type B:

Euro countries transfer their public debt up to a total of 60% („blue“ bonds) of GDP to an European agency (i.e. EMF) The EMF issues Euro Bonds to the financial markets. ECB guarantees market liquidity. Debt exceeding 60% of GDP remains financed individually („red“ bonds).

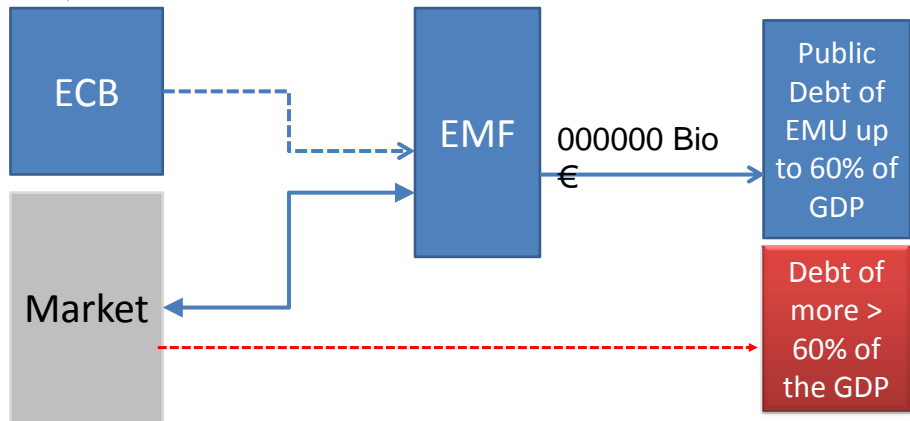

Prof. Dr. Rainer Stachuletz – Vietnam National University – September 2012

## Eurobonds – Liability and Sovereignty ?

### Euro Bond Model Type C:

Euro countries transfer their total amount of public debt exceeding 60% to a European agency (i.e. EMF in combination with sinking funds) The EMF issues Euro Bonds to the financial markets. ECB guarantees market liquidity. Additional debt needs the permission of an adequate European Institution

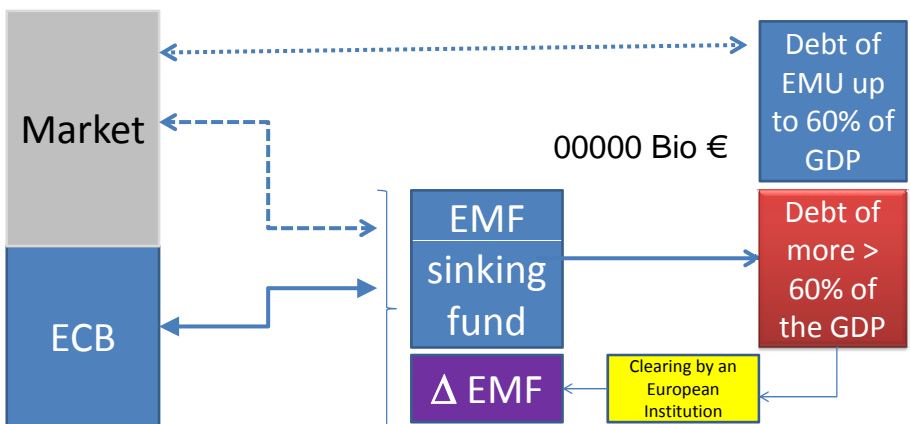

Prof. Dr. Rainer Stachuletz – Vietnam National University – September 2012

## Eurobonds – Outlook

- Clear message, that the Euro zone will remain in the future and the EU will probably step towards further integration. Market confidence will be re-established
- Interest rates effects depend on the model chosen. In general, rates paid by x-countries may decrease at cost of stronger economies. ESM will become a bank and enlarge it's portfolio. ECB becomes the lender of last resort.
- Without further economic and political integration, moral hazard will hamper budget discipline, reforms and the conversion process. The crisis may return

23

Prof. Dr. Rainer Stachuletz – Vietnam National University – September 2012

## EUM Political Integration – Assumptions

- Euro – Bonds are accepted as a viable solution to solve the current Euro crisis.
- A Road map to E-Bonds will include binding agreements to further integrative steps and transfer sovereign rights to EU-authorities:
  - Coordination and integration of the EMU - fiscal policy, taxation systems and budget laws
  - Coordinated economic and social policy
  - EU economic government to prevent from future macroeconomic imbalances in the Euro Zone
  - ESM will get a bank license
  - ECB becomes a „lender of last resort“

24

Prof. Dr. Rainer Stachuletz – Vietnam National University – September 2012

## Economic and Political Integration – Outlook

- EMU – countries that cannot agree upon closer integration will leave the monetary union following a binding exit procedure.
- Euro-bonds will be introduced and stepwise finance national budgets. The financial system will be supervised by EU - authorities. Bad banks are established and addressed to solve the NPL problems of EMU - banks.
- The future of the EU may see a European Federation of closely integrated countries and a European Free Trade Zone of others.

25

Prof. Dr. Rainer Stachuletz – Vietnam National University – September 2012

## Economic and Political Integration – Outlook

### **ESM becomes an European Debt Management Institution**

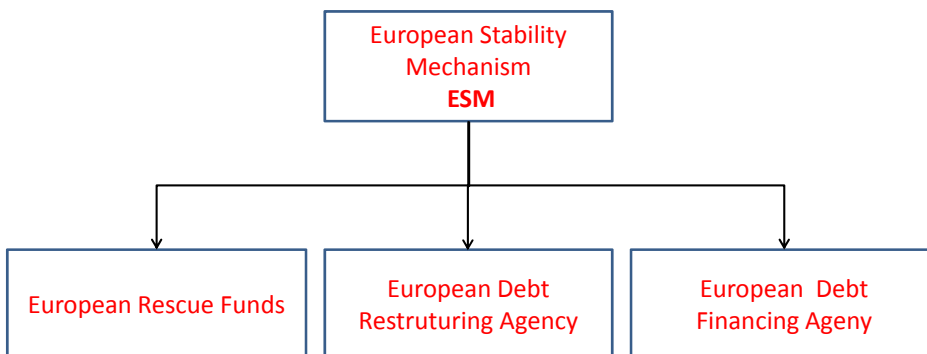

## Economic and Political Integration – Outlook

### **EGM becomes an European Economic Management Institution**



27

### Downfall or Resurrection - Assumptions

- Due to different orientations concerning fiscal, social and economic policy EMU and EEU fail to establish further integrating structures.
- One or more member - states will leave the Euro Zone and return to national currencies. Some countries may integrate their policies and continue the European currency, otherwise the whole system will break down.
- Financial and political consequences are disastrous. The break down of the financial system, economic recession and disintegration will substantially harm the European project.

28

## Downfall or Resurrection – Outlook

Some countries may turn away from the European project and return to their national currencies. The EU will temporarily disintegrate.

A downfall of the Euro would sharply increase the public and private debt burden. Insolvencies of countries, financial institutions and corporations may jeopardize the stability of the global economy. A worldwide bank crash and recession are most likely.

Europe continues as a smaller project (**Luxemburg ++**). A EU-Federation becomes the political and economic gravitation centre of Europe. The remaining EU will disintegrate and form to a Free Trade Zone.

29

Prof. Dr. Rainer Stachuletz – Vietnam National University – September 2012

## Downfall or Resurrection – Outlook

### Düstere Aussicht

Prognosen der wirtschaftlichen Folgen nach der Auflösung der Gemeinschaftswährung

Rückgang der Wirtschaftsleistung in den ersten zwei Jahren im Vergleich zum letzten Euro-Jahr, in Prozent



Arbeitslosenquote im zweiten Jahr, in Prozent



Verbraucherpreise Veränderung im Vergleich zum letzten Euro-Jahr, in Prozent



Quelle: IWE, eigene Berechnungen

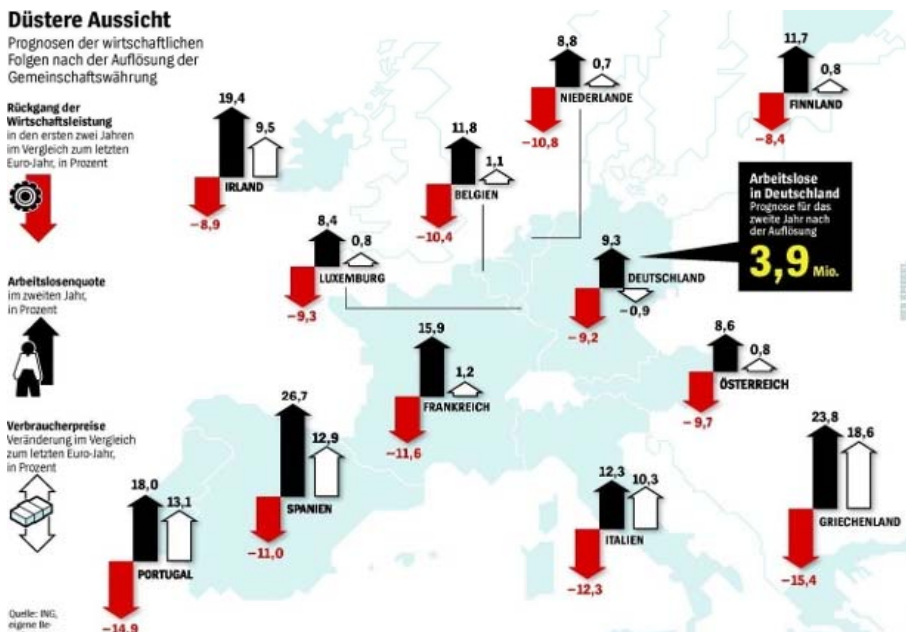

## Downfall or Resurrection – Outlook

A downfall of the EURO may lead to a substantially shrinking GDP. Concerning a selected set of countries, two years after a crash, the GDP may shrink by a total of about 915 Bio €. Assuming an annual recovery rate of 2% and a discount rate

COUNTRIES	GDP IN 2011 Billion Euro	TOTAL DEBT IN 2011 IN BILLION €	GDP AFTER CRASH	GDP LOSS AFTER CRASH IN BIO €
FRANCE	2.047,0	1.717,3	-11,60%	-237,5
ITALY	1.621,0	1.897,2	-12,30%	-199,4
GERMANY	2.627,0	2.088,5	-9,20%	-241,7
SPAIN	1.116,0	735,0	-11,00%	-122,8
BELGIUM	389,0	361,7	-10,40%	-40,5
PORTUGAL	170,0	184,3	-14,90%	-25,3
GREECE	217,0	355,6	-15,40%	-33,4
IRELAND	161,0	169,3	-8,90%	-14,3
<b>TOTAL</b>	<b>8.348,0</b>	<b>7.508,9</b>		<b>-914,8</b>

of 4%, the capitalized loss in terms of GDP may mount up to a total of 15 Trillion €. **Thus, a downfall of the Euro is neither an economic nor a political option.**

31

Prof. Dr. Rainer Stachuletz – Vietnam National University – September 2012

## Resumé

- To continue the European Project the € crisis must be solved.
- A Separation of currency regime and political union does not work. The Euro without fiscal, social and political integration is not viable.
- Technically the introduction of Euro Bonds are welcomed to stabilize the Euro and calm the markets.
- Joint Liability requires – as a price - closer fiscal, social and political integration.

32

Prof. Dr. Rainer Stachuletz – Vietnam National University – September 2012



## Resumé

- The treaty on fiscal stability and growth should be ratified and implemented as national law at a constitutional level.
- A coordinated European fiscal and economic policy will be redesigned. Substantial sovereign rights will be transferred and controlled by legitimate EMU authorities.
- The EU will see two connected kinds of membership organizations: The European „Federation“ and the European Free Trade Zone.

33

# Thank you !!

34